



## HUMIDITY AND TEMPERATURE Conditioner Sensors

### G-TUCN.34

This micro-module, designed to quantify the **relative humidity level and the temperature** in the ambient atmosphere, delivers a variable frequency proportional to the humidity, associated to a resistive temperature sensor (thermistor NTC).

Designed using SPSI UPSICAP *MSS Bi-face* technology this micro-system *integrates* a humidity cell created in-situ on the upper side of the substrate, while, the lower side carries the temperature sensor, the electronic transmitter and the plug-in connector. This active system, which has one of its flat side sensitive to ambient relative humidity, is protected by full moulding under vacuum.

This sensing side to humidity is covered with a high efficient atmospheric filter in order to reduce electrical effects of condensation.

This internationally patented technology is a major step forward in the field of sensor-transmitters with long-term stability and reduction of mass production cost.

- MSS Bi-Face original concept***
- Exclusive SPSI technology***
- Micro-system with digital output***
- High accuracy - High reliability***
- Moulded plug-in module***
- Complementary atmospheric filter***
- Operating from 0% to 100% RH, -40 to +100°C***
- Ultra fast response***
- Total interchangeability without recalibration***
- Instantaneous desaturation***
- Output current up to  $\pm 2$  mA***
- Best quality-price ratio on the world market***
- Integrated production***

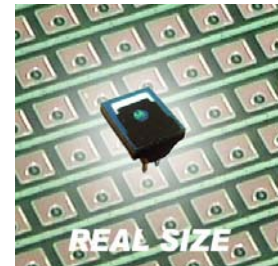

### MAIN CHARACTERISTICS

- |  |   |
|--|---|
| ➤ Qualified measurement range                  | 2 % RH to 98 % RH, -40° C to + 85° C                        |
| ➤ Time constant humidity                       | 0.9 or option Rx or Lx                                      |
| ➤ Operating temperature                        | - 40°C to +100°C  |
| ➤ Accuracy (calibration – interchangeability)  | $\pm 3$ % RH, $\pm 1^\circ$ C (option $\pm 2$ % RH, 0.25°C) |
| ➤ Nominal internal power consumption           | 0.001 W under 5 V   |
| ➤ Recovery time 100 % RH 105 h                 | 2 sec. or according on model Rx or Lx                       |
| ➤ Output signal                                | 0-5 V Variable frequency square waves, NTC                  |
| ➤ Operating power supply voltage               | 4 V to 10 VDC   |
| ➤ Rated power supply voltage                   | 5 Vdc   |
| ➤ Humidity basic transfer function             | $F = F_{55} (1.108 - 0.002\% \text{ RH})$                   |
| ➤ Standard calibration ( $F_{55}$ , $T_{25}$ ) | 6500 Hz at 55 % RH, 10 K $\Omega$ at 25 ° C                 |
| ➤ Temperature transfer function                | $R = 0.119.e^{3380 / (T+273)}$                              |
| ➤ Thermal sensitivity RH                       | $\pm 0.05$ % RH / °C  |
| ➤ Parallelepipedic dimensions                  | 9 mm (L) x 8 mm (l) x 5 mm (h)                              |

**ORIGINAL TECHNOLOGY UPSICAP – MSS BI-FACE**

*UPSI* product range are based on two fundamental concepts *UPSICAP* and *MSS Bi-Face* elaborated and developed by the *Société d'applications électroniques pour la Physique, la Science et l'Industrie* (international patent <http://www.patentstorm.us/patents/6450026-claims.html>)

**The MSS Bi-Face concept incorporates on the same substrate both, the humidity sensor on the main face and electronic device, including connections, on the opposite side.**

The humidity cell is not added on the substrate but carried out directly *in situ* .

Accuracy, stability and reliability are improved, connecting the sensor to the acquisition electronic circuit with continuum solid vias excluding link wires or printed circuit.

The surface electrode in contact with water vapor is connected to 0V (ground) provides shielding against surrounding electrical field and its thickness provide high robustness atmospheric filter.

The absence of electrical connections on the sensitive face does away with a barrier irregularity reducing the airborne dust on this side and enhancing reliability in the event mechanical action affecting the cell.

For harsh environment, a complementary filter could be placed on the sensing side.

The additional function (transmitter) component quantity is divided by 2 using some multifunction device increasing the reliability and decreasing area and cost (original electronic concept).

**This technology allow to supply an analogic or digital sensor transmitter with 100 μW - 20 μA.**

The operating range until 100% RH is insured by a specific treatment (substrate and components impregnation).

**TRANSFER FUNCTIONS**

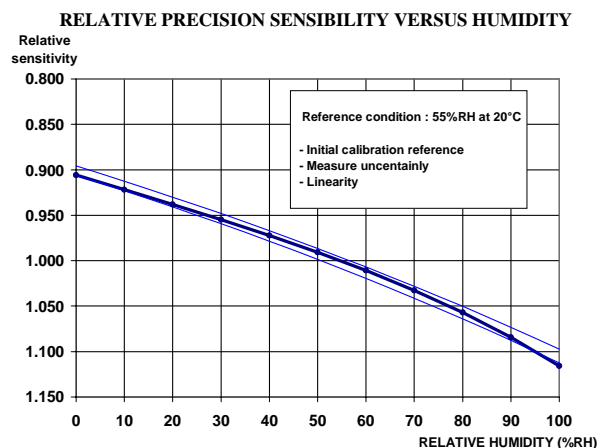
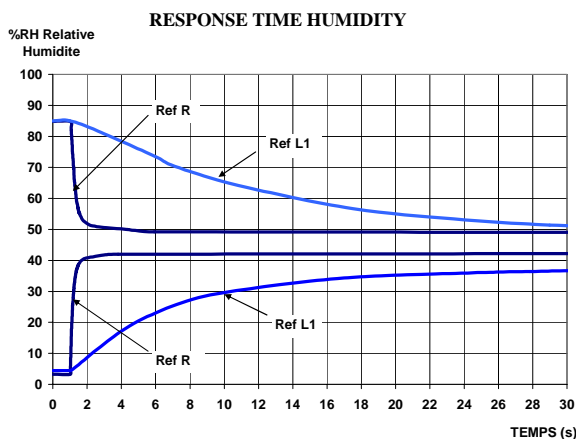
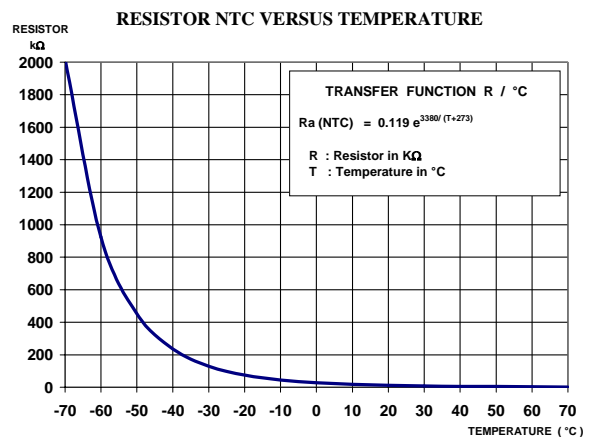
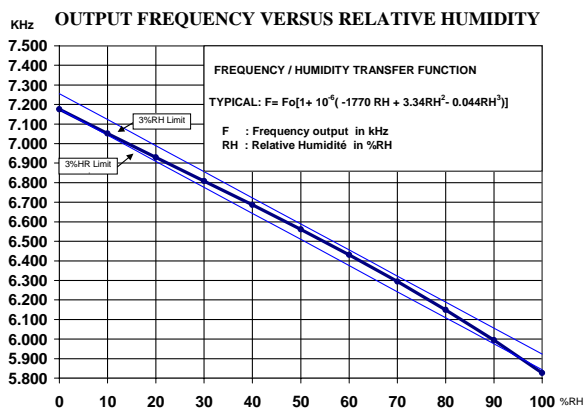

**ELECTRICAL AND MEASURING SPECIFICATIONS**

Measured or influencing values	Définition	Values			Unit
		Min.	Nom.	Max.	
<b>Relative humidity RH</b>	RH measuring range	2	→	98	% RH
	RH operating range	0	→	100	% RH
	Hysteresis		< 1,5		% RH
	Accuracy according to reference conditions	2	3		% RH
	<b>Conformity error (2 % RH to 98 % RH)</b>		1.5		% RH
	Time constant Fast version R1	0.25 ↑	<b>0.30</b>	0.40 ↓	sec.
	Version L1	0.9 ↑	<b>1</b>	1.1 ↓	sec.
	Recovery time (100 % RH 150 hours)		2		sec.
	Absolute humidity Specified metrology		0.12		Kg/Kg
Maximum Metrology outside tolerance		0.35		Kg/Kg	
Degraded metrology		0.5		Kg/Kg	
<i>Output signal</i> Hz / %RH	Nominal Variable frequency Square wave / RH	7 176	→	5 826	Hz
	High level time / Low level time	1.15	1.18	1.21	Th/Tb
	Square waves amplitude (output current = 0)	0.99 Vcc		Vcc	V
	Measuring current (input or output)	0	→	± 2	mA
	Source resistance		250		Ω
<i>Transfer</i>	$F(\text{Hz}) = 7176 - 12.7 \text{ RH} + 0.024 \text{ RH}^2 - 0.00032 \text{ RH}^3$				
	Standard calibration 12 % RH	6 970	7 027	7 080	Hz
	F55 = 6500 Hz 55 % RH	<b>6 460</b>	<b>6 500</b>	<b>6 540</b>	Hz
	97.5 % RH	5 790	5 870	5 950	Hz
Sensitivity (33 % RH to 76 % RH)	12,7	13,1	13,3	Hz/%RH	
<i>Electrical power supply</i>	Supply voltage Vcc	4	5	10	V
	Supply current Icc (output current excluded)	0.15	0.17	0.25	mA
	Power supply (output current excluded)	0.6	0.8	3.0	mW
<i>Stability</i>	Instantaneous modulation (noise)	0.005	0.01	0.05	% RH
	Sensitivity to supply voltage (Vcc)		0.1	0.2	% RH/V
	Error for Vdc = 4.75 V to 5.25 V		± 0.02	± 0.04	% RH
	Thermal sensitivity	0.03	0.04	0.05	%RH/°C
	Thermal stability from 0° C to 50° C		± 1.5		% RH
Capacitive sensitivity (line capacitor Cp)		0.01		%RH/nF	
<b>Ambient Ta temperature</b>	Range of measurement	- 40	→	+ 100	°C
	Accuracy to the reference conditions	0.25	1		°C
<i>Output signal</i> Ω / °C	Nominal resistive value at 25° C		10		KΩ
	Maximum current		0.3		mA
<i>Transfer</i>	$R = 0.119 e^{3380 / (T+273)}$ (accuracy 1°C)				Ω
	$T = 1/[A+B.\ln R+C.(\ln R)^3]$ (accuracy 0.25°C)				
<b>Temperature</b>	Long term storage	- 50	+ 25	+ 85	°C
	Specified operating range	- 30	+ 25	+ 85	°C

**MECHANICAL SPECIFICATIONS - ELECTRICAL CONNECTION**

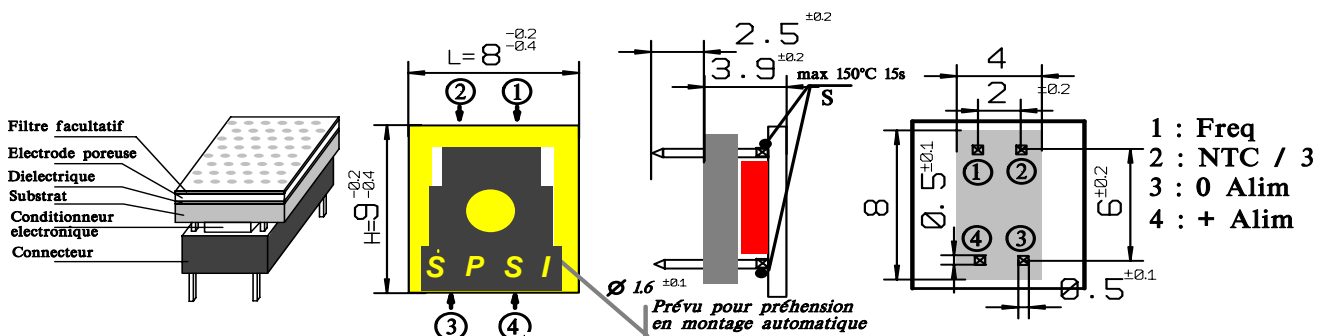

**APPLICATIONS**

**UNITE DE PRODUCTION DE SYSTEMES INDUSTRIELS**

S.A.R.L au capital de 660 000 € RCS Créteil B 433 547 643 Siret 433 547 643 00018 Code NAF 321 C  
ZI des Grands Godets – 951 Rue Marcel Paul – 94500 CHAMPIGNY/MARNE-FRANCE

**Tél : +33 1.45.16.18.20 – Fax : +33 1.45.16.18.29 – courriel : [contact@upsi.fr](mailto:contact@upsi.fr) - Site web : [www.upsi.fr](http://www.upsi.fr)**